

NOV 1969

NANOSECOND X-RAY DIFFRACTION:
STUDY OF SOLIDS UNDER SHOCK COMPRESSION

Quintin Johnson, A. Mitchell, R. Norris Keeler and L. Evans

Lawrence Radiation Laboratory, University of California
Livermore, California 94550

INTRODUCTION

In experiments which have previously been reported,¹ we have shown that it is possible to obtain powder patterns of materials in nanosecond time intervals with the aid of a "Blumlein" flash X-ray device. In view of the orders-of-magnitude decrease for exposure time compared to conventional techniques, it is reasonable to expect that many novel and interesting applications will result. One such application, suggested in the earlier paper, is the study of materials while under shock compression. We wish to report on the status of experiments of this type conducted at Lawrence Radiation Laboratory.

EXPERIMENTAL

The experimental problems associated with the attempt to observe X-ray diffraction from materials under shock compression *This work was performed under the auspices of the U. S. Atomic Energy Commission.

come under three headings. First, a very intense X-ray source is required which has a pulse width greater than about 10 nsec and can be turned on in less than 10 μ sec with jitter less than 100 nsec. Second, it is necessary to subject the sample to a shock impulse, preferably of pressure greater than 10 kbar, by a technique subject to the constraints of the remainder of the experiment. Third, a detector system is needed which can either be protected from the effects of the shock loading or which can respond in nanosecond time intervals and be sacrificed.

X-ray Source

The X-ray source used in these experiments was constructed following the principles described by Blumlein² and Fitch and Howell.³ In brief, this consists of a three-conductor coaxial transmission line with a switch at one end and an evacuated electrode gap at the other (see Fig. 1.). Alternate layers of conductor and dielectric form a 20-cm-diameter, 4.9-m-long, hollow

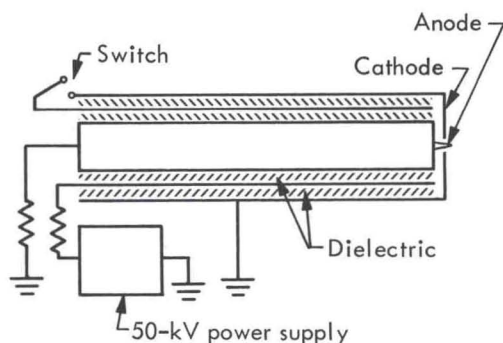

Fig. 1. Blumlein flash X-ray unit.

cylinder. The innermost conductor is grounded at the switch end and connected to the anode at the gap end; the middle conductor is connected to a 50-kV power supply at the switch end; the outside conductor is grounded and connected to the cathode. Switching is accomplished by exploding a small detonator which breaks down an insulated gap between the outside and middle conductors. This method takes approximately $3 \mu\text{sec}$ to turn on the X-rays, and is reproducible to about $\pm 50 \text{ nsec}$. The X-ray pulse width is 20-30 nsec. The machine used in these experiments is capable of a peak cathode current of approximately 40 kA and a peak anode voltage of approximately 85 kV.

Shock Loading

Several methods could be used

to subject the sample to pressures exceeding 10 kbar. The simplest physical configuration places the sample in contact with a piece of high explosive. The constraints of the experiment, however, require that both the X-ray tube and detector be close to the sample and very nearly in the way of the expected debris. Unless cleverly shielded, this equipment would be lost. Preliminary results with this method have not been encouraging.

Of a somewhat less destructive nature are the methods employing flying projectiles, especially those which do not depend upon an explosive chemical reaction for the acceleration. One such method which is especially non-destructive is that of the magnetically-driven flying plate. A thin plate of aluminum is accelerated across a small gap by the magnetic force arising out of a current surge through a conductor. There are no gases to contend with, and the only debris is the aluminum plate which has a velocity less than $0.25 \text{ mm}/\mu\text{sec}$ for pressures of interest. The experimental arrangement using this method of shock loading is shown in Fig. 2.

Of interest is the projectile tilt. This has been measured with a streak camera and is less than $15 \text{ nsec}/\text{mm}$ for the worst case.

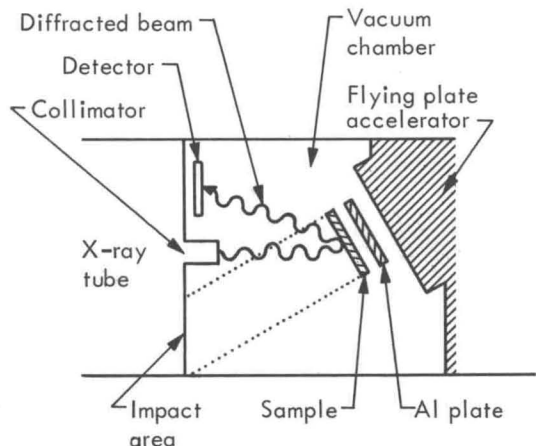

Fig. 2. Geometry of the dynamic X-ray experiment.

Since the beam is fairly large (~ 3.0 mm), this constitutes a severe problem if we desire quantitative data, but simply an additional source of timing uncertainty if we only seek qualitative results.

The velocity of the projectile was measured by experiments in which the flying plate impacted onto samples containing three or more pressure-sensitive pins located at known spacings in front of and in the sample. This velocity before impact is 0.24 ± 0.02 mm/ μ sec. It is difficult to measure shock velocities through the sample under the conditions imposed by this experiment. Measured values were 3.0 ± 0.5 mm/ μ sec, which is considerably

lower than expected based on the measurements of Al'tshuler et al.⁴ The cause of this is uncertain, but is probably a combination of the method of measurement, tilt, and the fact that a substantial amount of binder had been added to the sample to stabilize it. Since we require only qualitative results at this stage, this uncertainty contributes to the timing error but is not otherwise a problem. Timing calculations were made on the basis of 3.0 mm/ μ sec.

Detector System

In view of the relatively non-destructive nature of the flying plate, it was felt that it might be possible to detect the lines from the sample under shock compression with the aid of a film placed on the cathode plate of the Blumlein. It is desirable to tilt the sample as much as possible in order to minimize the damage to the X-ray tube and film. On the other hand, this detracts from the diffraction intensity in the useful region. The trade-off between the tilt angle, as defined in Fig. 3, and the azimuthal angle ϕ is mirrored in the following equation:

$$I = \frac{k}{\mu} \left[1 + \frac{1}{\cos 2\theta - \tan \gamma \sin 2\theta \cos \phi - 1} \right]$$

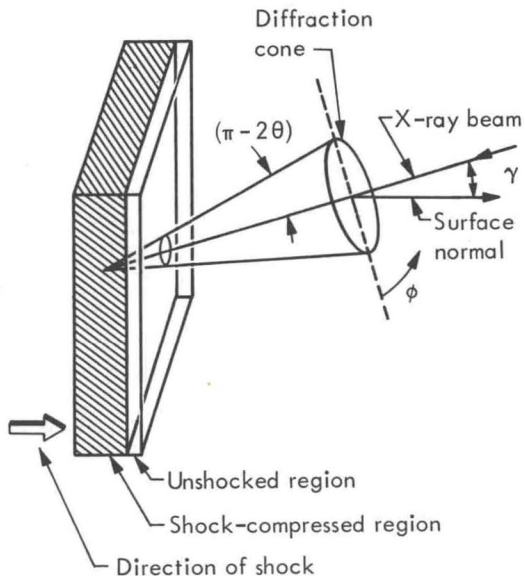

Fig. 3. Diffraction from a flat sample tilted with respect to the X-ray beam. Direction of shock impulse is normal to sample surface.

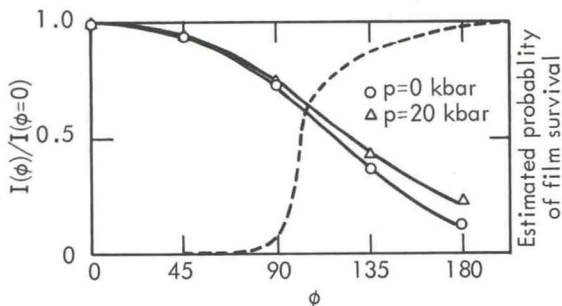

Fig. 4. Intensity variation of the 422 reflection of LiF at $p = 0$ and $p = 20$ kbar of pressure as a function of the azimuthal angle. Qualitative estimate of the probability of film survival as a function of the azimuthal angle is indicated by the dotted line.

Here μ is the linear absorption coefficient and k is a constant relating to the beam intensity and the structure factor for the reflection.

This function, normalized to $I = 1$ at $\phi = 0$, is plotted in Fig. 4. The experimental parameters for this evaluation are:

Anode material	= Cu
Sample	= powdered LiF
γ	= 45°
hkl	= 422
Source to sample distance	= 45 mm

These curves give the expected intensity variation for the case that all of the sample is either at $p = 0$ or at 20 kbar. The dotted line is a qualitative estimate of the likelihood that a film placed at ϕ would survive the experiment. We wish to maximize the intensity without sacrificing the film. The best way to do this is to let the experiment dictate the lowest value of ϕ which can be recovered. This is done by placing the film over most of the region $45^\circ < \phi < 180^\circ$. The aluminum plate and sample debris destroy the film in the impact region, but above this region the film is sometimes useable.

For $p = 0$ kbar, the 422 line is visible throughout most of the region of ϕ , especially after chemical

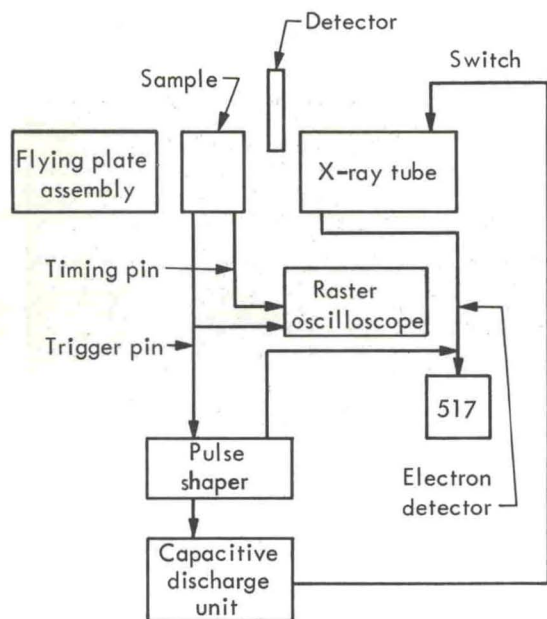

Fig. 5. Diagram of the equipment involved in the dynamic X-ray diffraction experiment.

intensification of the image.

The experimental arrangement is shown in Fig. 5. Two pins were located in the sample. One, projecting through the back, served as a trigger pin which initiated the X-ray firing. The other, set in the sample, served to indicate if the timing was correct.

For the actual experiment, the film was exposed to X-rays twice. In the first exposure taken under normal pressure conditions, part of the diffraction ring was obscured by lead shielding. A second exposure was then taken with the sample under shock compression and the lead

shielding removed. The effect of 15 kbar of pressure would be to shift the 422 line by about 2° in 2θ , and would be expected to be most noticeable in the part of the film where the singly exposed region adjoins the doubly exposed region.

Eight experiments were carried out using film for a detector. Results as discussed below were unsatisfactory because of the very low X-ray beam intensity. Difficulties with this approach led us to explore the possibility of using scintillation detectors instead.

Since the X-rays are on for less than 30 nsec, a period of time too short to permit pulse height resolution, it is necessary to somehow scan the 2θ angle in order to obtain a plot of the intensity versus 2θ . This can be done in at least two ways. Perhaps the best way is to position one scintillation detector at every 2θ point where sampling is required. A less satisfactory method is to provide at least two detectors -- one to monitor the main beam and the other to scan the 2θ region in a series of experiments. Both require the development of a two-detector system capable of fast resolution.

Detectors were built using a plastic fluor as a scintillation material coupled to a photomultiplier by means of a light pipe. The output

was recorded on a Tektronix 585 oscilloscope. Two complete units were assembled. The noise level at the oscilloscope was reduced by careful attention to shielding and grounding. A diagram of the detector arrangement is shown in Fig. 6. These detectors were placed in the region where experience had shown film could survive. A typical oscilloscope record of an X-ray pulse using these detectors is shown in Fig. 7. Eight experiments were carried out using the scintillation detectors. The results are described below.

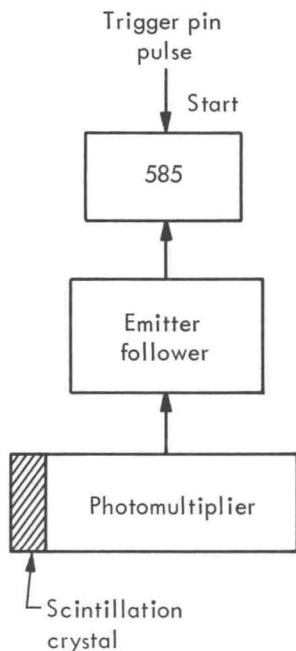

Fig. 6. Diagram of the scintillation detector equipment.

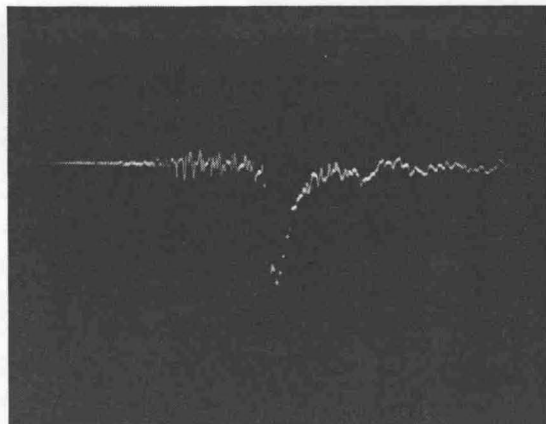

Fig. 7. Typical oscilloscope record of the X-ray pulse obtained with the scintillation detector. Pulse width is about 30 nsec.

DISCUSSION OF RESULTS

The experiments using film as a detector were rather inconclusive. Most of these failed because of timing difficulties. The nature of the problem can be understood by substituting experimental parameters into the following equation which yields the ratio of the intensity diffracted from a sample thickness t to that diffracted from the total thickness:

$$\frac{I(t)}{I(\infty)} = 1 - \exp \left[-\mu t \left(\frac{1}{\cos \gamma} - \frac{1}{\cos \gamma \cos 2\theta - \sin \gamma \sin 2\theta \cos \phi} \right) \right]$$

This ratio is equal to 0.95 for $\phi = 90^\circ$ and $t = 0.29$ mm. This means that 95% of the diffraction comes

from less than 0.3 mm of the sample. We must therefore carefully turn on the X-rays at a time such that the shock front is in this region, preferably only 30 nsec before the shock breaks out of the front surface. For an assumed shock velocity of 3 mm/ μ sec, this experimental window is only 100 nsec wide. Since the Blumlein jitter is ± 50 nsec, the jitter introduced by variation in flying plate velocity is ± 100 nsec and miscellaneous other problems probably introduce at least another ± 100 nsec, it is not unreasonable to expect a low success ratio.

One film after intensification showed a slight shift in the 422 line at the single-double exposure boundary. Although this shift was in the correct direction, it was not equal to the amount predicted. Several explanations for this could be suggested. We consider it unlikely that this shift could be the result of the sample moving toward the X-ray tube. This would have required a timing error far larger than our timing results indicated. Another possible explanation is that the "shifted" line is an artifact introduced by the intensification process. Again, this is not likely since the film itself was untreated and only prints made from it were treated. The

apparent shift was visible to a greater or lesser extent on all of the prints. A somewhat more plausible explanation is that the line comes from the sample under compression but at a pressure somewhat lower than expected. Measurement of the actual pressure on the sample would serve to confirm or refute this theory.

The results with the scintillation detectors were equally inconclusive. Timing difficulties forced us to abandon attempts at scanning in 2θ . Rather, we attempted to observe a significant change in the ratio of the intensity at the 2θ region appropriate for diffraction from a sample under about 10-15 kbar pressure to the intensity at the normal region. One experiment showed a ratio of 1.2 in the static event and 2.0 for the dynamic event. All other experiments were unsuccessful because of timing errors and equipment malfunction.

While it would be premature to claim that these two experiments constitute proof that it is possible to observe diffraction from materials under shock compression, they are nevertheless encouraging. The future success of this type of experiment is dependent upon advances being made in higher intensity X-ray tubes, better control of timing, and the development of an array of detectors.

ACKNOWLEDGEMENT

We thank C. Dittmore, R. Jacobson, J. Schimmel, W. Vandermolen and J. Wengert for assistance in these experiments.

REFERENCES

1. Q. Johnson, R. N. Keeler and J. W. Lyle, *Nature* 213, 1114 (1967).
2. A. D. Blumlein, *British Patent No. 589*, 127, June 12 (1947).
3. R. A. Fitch and V. T. S. Howell, *Proc. Inst. Elec. Eng.* 3, 849 (1964).
4. L. V. Al'tshuler, M. N. Pavlovskii, L. V. Kuleshuva, and G. V. Simakov, *Soviet Phys.-Solid State* 5, 203 (1963).

DISCUSSION

R. E. Hanneman - General Electric Research and Development Center, Schenectady

Q: Was the diffracting portion of the sample really isobaric during the entire X-ray exposure?

A: The X-ray pulse must be turned on during the approximately 100 nanosecond wide experimental window. If this is done properly, diffraction

should result from material under two different pressures. The region not yet reached by the shock impulse is at normal pressure, while all the region behind is at the elevated shock pressure.

Hanneman

Q: What was the pressure interval where you obtained successful results?

A: The experiment was designed to reach a 10 to 15 kilobar pressure.

Moore

Q: Do you find the scintillation counter fast enough for these kinds of experiments?

A: Yes

Moore

Q: A lithium drifted silicon diode is faster by a factor of 10. You might get a gain in efficiency.

A: Well, the most significant problem with any detector is the problem of noise and you're really fighting it with something like that. We're dealing with currents of about an Amp coming out of our photomultiplier. I don't know if you can get that out of a silicon detector.